



This manual contains important safety information regarding the installation and operation of the device. Carefully follow this information to prevent personal injury and property damage.

Keep the pump protected from sun and rain.
Avoid splashing water.



WNPHRH / WNPCL OPERATING MANUAL



ENGLISH version

R060525

Descrizione Prodotto
Product Description

Pompa dosatrice elettromagnetiche, serie W
Electromagnetic dosing pump, W series

Codici Identificativi Prodotto

(I simboli "-" completano il codice del prodotto in base alla configurazione delle varianti)

Product Identification Codes

(The "-" symbols complete the product code based on the configuration of the variants)

WAA -----	WHL -----	WTM -----
WAB -----	WHO -----	WTP -----
WAD -----	WHR -----	WUS -----
WAC -----	WHS -----	WVE -----
WAH -----	WLS -----	WNA -----
WAL -----	WOP -----	WNH -----
WAR -----	WPC -----	WNE -----
WAS -----	WPD -----	WNC -----
WAT -----	WPH -----	WNL -----
WAU -----	WPS -----	WNP -----
WBS -----	WRA -----	WNS -----
WCR -----	WRF -----	WNV -----
WDA -----	WRR -----	WZH -----
WDD -----	WRS -----	WZE -----
WDF -----	WSA -----	WZC -----
WDH -----	WSH -----	WZS -----
WDL -----	WSO -----	WZV -----
WDR -----	WSP -----	WZP -----
WDS -----	WSR -----	WZA -----
WEV -----	WSS -----	
WHA -----	WT4 -----	
WHH -----	WTC -----	

1. Introduction

WN-STEPPER is an advanced programmable instrument equipped with two peristaltic dosing pumps with stepper movement for the precise dosing of acid (pH) and disinfectant (Redox) or Chlorine (Cl₂) with integrated temperature readout. Designed for installation in swimming pools, it allows constant monitoring of essential water parameters. The unit supports On/Off or proportional operating modes, which can be adjusted according to the setpoints. In addition, the AUTO DOSING function automatically optimises dosing according to the volume of the pool and the diameter of the internal hose of the peristaltic pumps. Ideal for new construction projects, WNP_{Hxx} model introduces an innovative wall-mounting solution, minimising space requirements.

- pH scale: 0-14 pH
- Redox scale (model WNP_{HRH} only): 0-999 mV
- Chlorine scale (model WNP_{HCL} only): 0-10 mg/l Cl₂
- Chlorine probe (model WNP_{HCL} only): ECL6; ECL12, SCL, SVCL
- Temperature Probe: 0-100 °C

Information is shown on a large LCD display. Using the innovative ENCODER, the device can be easily programmed, connected to the internet, and controlled remotely, even via an APP. WNP_{Hxx} is housed in an IP65 plastic box (IP54 model with peristaltic pump).

2. ENCODER

The instrument control encoder is located in the upper right corner. This dial can be rotated in either direction to scroll through the menus and pressed to select the highlighted item.

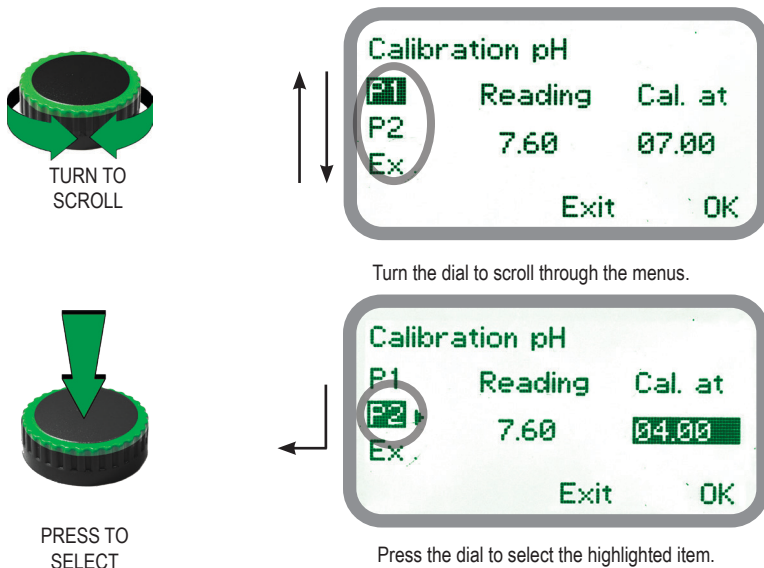

3. WNPHRH CONNECTIONS

Disconnect the instrument from the power supply to make connections to the selected probes and/or outputs according to the figure below.

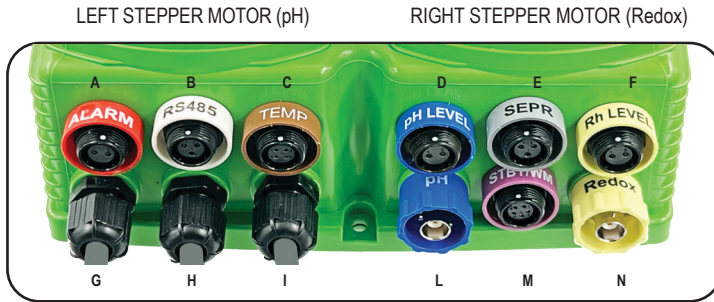

Use the rubber caps to protect the connections not in use.

NAME	PIN CONNECTOR CONTACT		
A) Alarm Contact	1: contact	2: contact	
B) RS485	1: +RS485	2: -RS485	3: Termination PIN
C) Temperature Probe	1 and 3 : PT100 (yellow/white)		2 and 4: PT100 (green/blue)
D) pH level	1: contact	2: contact	
E) Proximity Sensor			
F) Redox Level	1: contact	2: contact	
G) Instrument Power Supply: 90/240 VAC 50-60Hz			
H) VAC OUT1	Programmable 90/240VAC output ("VAC OUT1 SETTING" menu) as a power supply - MAX LOAD 8A		
I) VAC OUT2	Programmable 90/240VAC output ("VAC OUT2 SETTING" menu) as power supply - MAX LOAD 8A		
L) pH probe			
M) Standby/WaterMeter	1: WM signal (brown)	2: WM GND (blue)	3: n/c (yellow)
	4:STANDBY signal (green)	5: Standby GND (white)	
N) Redox probe			



CAUTION: connections must be made by experienced and qualified personnel only after disconnecting the instrument from the main power supply

3.1 WNP HCL CONNECTIONS

Disconnect the instrument from the power supply to make connections to the selected probes and/or outputs according to the figure below.

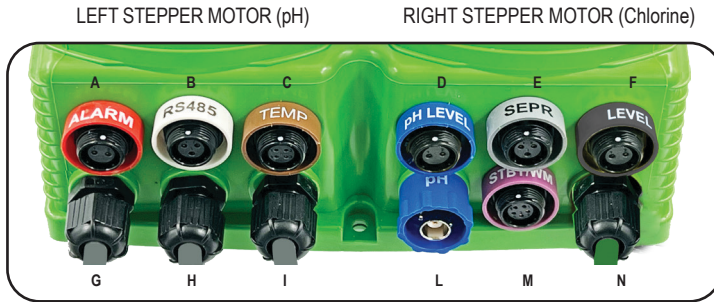

Use the rubber caps to protect the connections not in use.

NAME	PIN CONNECTOR CONTACT		
A) Alarm Contact	1: contact	2: contact	
B) RS485	1: +RS485	2: -RS485	3: Termination PIN
C) Temperature Probe	1 and 3 : PT100 (yellow/white)		2 and 4: PT100 (green/blue)
D) pH level	1: contact	2: contact	
E) Proximity Sensor			
F) Disinfectant Level	1: contact	2: contact	
G) Instrument Power Supply: 90/240 VAC 50-60Hz			
H) VAC OUT1	Programmable 90/240VAC output ("VAC OUT1 SETTING" menu) as a power supply - MAX LOAD 8A		
I) VAC OUT2	Programmable 90/240VAC output ("VAC OUT2 SETTING" menu) as power supply - MAX LOAD 8A		
L) pH probe			
M) Standby/WaterMeter	1: WM signal (brown)	2: WM GND (blue)	3: n/c (yellow)
	4: STANDBY signal (green)	5: Standby GND (white)	
N) Chlorine Probe (BNC for version ECL6 - 5-wire cable SCL version with green wire not connected)			
	1: Brown wire (-RS485)	2: White wire (+RS485)	
	3: Yellow wire (GND)	4: Blue wire (+5 VDC)	



CAUTION: connections must be made by experienced and qualified personnel only after disconnecting the instrument from the main power supply

3.2 Hydraulic connections

Disconnect the instrument from the power supply to make connections to the probes, the selected outputs and the hydraulic ones. The hydraulic connections are:

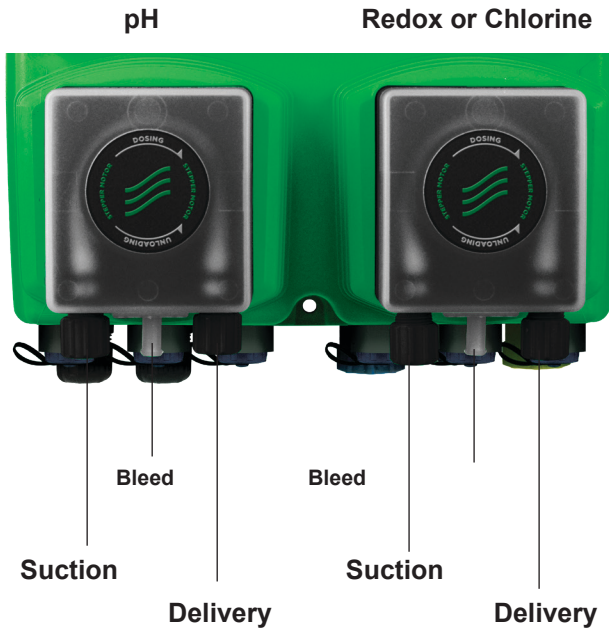

Caution: the bleed hose should be inserted into the tank of the product to be dosed. If left free it could damage property and people.

PERISTALTIC CAPACITY / Pipe Ø4.8x1.6		
Pressure	Flow Rate Range	RPM range
bar (psi)	l/h (gal/h)	rpm
2 (29)	0.12-12 l/h 0.0317-3.17 gal/h	1 - 100

PERISTALTIC CAPACITY / Pipe Ø1.6x1.6		
Pressure	Flow Rate Range	RPM range
bar (psi)	l/h (gal/h)	rpm
2 (29)	0.018-1.8 l/h 0.0047-0.47 gal/h	1 - 100

3.3 Hydraulic connections, level probe

Assemble the foot filter with the level probe. The level probe must be assembled using the special kit supplied with foot valve. The foot valve is designed to be installed at the bottom of the product container without any problem of sediment suction.

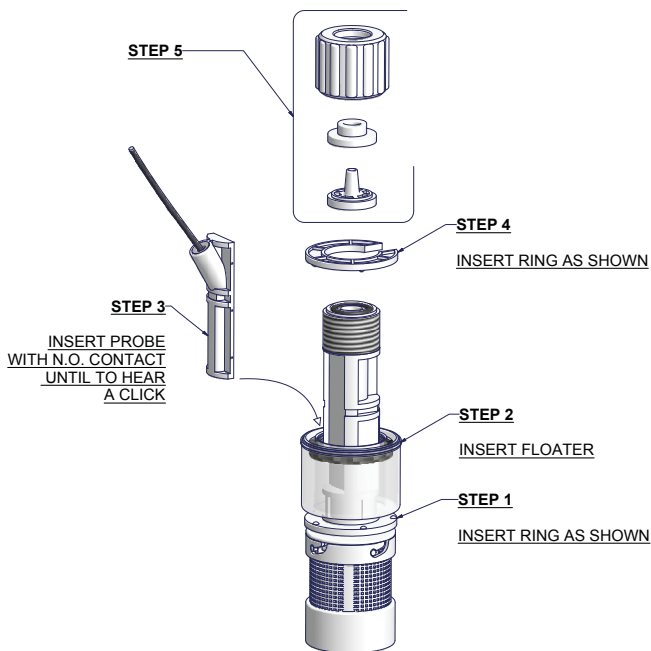

Connect the BNC on the level probes to the level inputs of the WNPHxx (connectors "D" and "F").

Insert the level probe with the foot filter assembled at the bottom of the tank of the product to be dosed.

Note: If there is a mixer in the container, a suction lance must be installed.

4. Main WNPHRH screen

The following main screen will appear in normal operating mode:

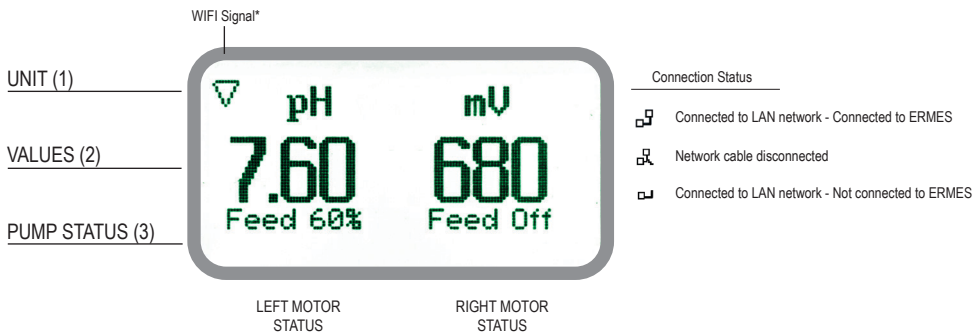

The main screen is divided into 3 zones.

(1) UNIT "pH" is the pH probe unit of measurement.
"mV" is the unit of measurement of the Redox probe.

(2) VALUES These numbers are the values read by the probes.

(3) PUMP STATUS These fields indicate the current status of the pumps and the instrument activity.
E.V. status (WNPHxx EV mod. only)

DISPLAY MESSAGE	MEANING	WHAT TO DO
FEED ON	The pump is dosing the chemical	No action required
FEED OFF	The pump is OFF	No action required
LOW TANK	The chemical tank is almost empty	Check the tank - Restore the correct level
NO FLOW	The external contact has blocked the pumps	Check the flow
OK	Setpoint has been reached	No action required
FEED LIMIT	The dosing time has been reached. Dosing alarm	Check the pump flow rate
PROBE FAIL	Probe reading value blocked	Check that the probe is working properly
DELAY	Pump activity cancelled. Start countdown	If not requested, check the PARAMETERS option
WAIT PH	Prioritise pH dosing over Redox dosing	If not requested, check the PRIORITY option
POWER SUPPLY OUT OF RANGE	Power supply voltage is out of range.	Check the power supply voltage

4.1 Main WNPCL screen

The following main screen will appear in normal operating mode:

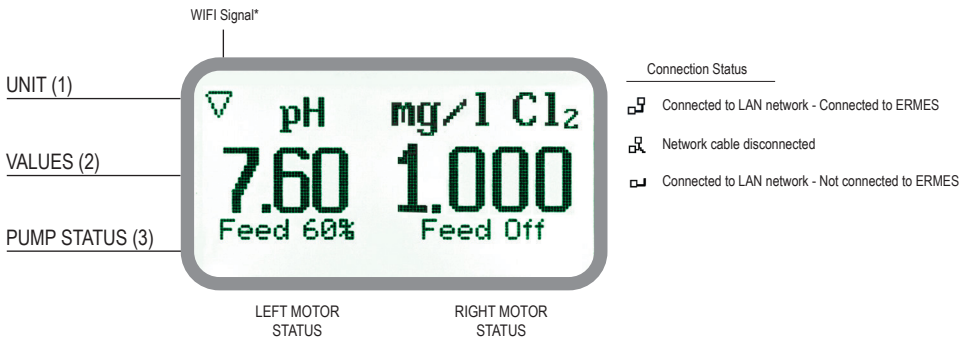

The main screen is divided into 3 zones.

- (1) UNIT "pH" is the pH probe unit of measurement.
"mg/l" is the unit of measurement of the Chlorine probe.
- (2) VALUES These numbers are the values read by the probes.
- (3) PUMP STATUS These fields indicate the current status of the pumps and the instrument activity.

4.2 Display colours

The display background changes colour according to the operating situation:

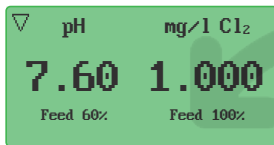

GREEN: Normal operation

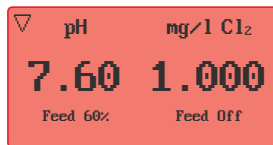

RED: Alarm

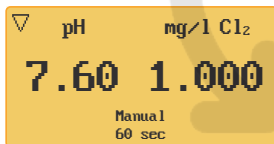

YELLOW: Warning











WHITE: Standby

In the event of an alarm or warning, check the system status ("Status") by rotating the encoder from the main screen.

5. Quick status check

Turn the dial on the main menu to look through the main parameters of the instrument and the operating status.

	<div style="border: 1px solid gray; border-radius: 10px; padding: 5px; width: fit-content;"> <p style="text-align: center;">Status</p> <p>Hour: 16:35:58 Date: 03-01-1970 pH: 7.60 mV: 680</p> </div>	<p>Current time Current date Current pH reading Current Redox reading</p>
	<div style="border: 1px solid gray; border-radius: 10px; padding: 5px; width: fit-content;"> <p style="text-align: center;">Status</p> <p>Dosing alarm: NO Probe fail: NO Flow: NO Level: NO</p> </div>	<p>Dosing alarm condition Probe malfunction NO FLOW contact status Level contact status</p>
	<div style="border: 1px solid gray; border-radius: 10px; padding: 5px; width: fit-content;"> <p style="text-align: center;">Status</p> <p>Cal.pH fail: YES Cal.pH day: 01/01/21 Cal.mV fail: YES Cal.mV day: 01/01/21</p> </div>	<p>Result of last pH calib. Date of last pH calibration Result of last Redox calib. Date of last Redox calibration Temperature Detected by the Probe</p>
	<div style="border: 1px solid gray; border-radius: 10px; padding: 5px; width: fit-content;"> <p style="text-align: center;">Status</p> <p>Day Calib Ch1: 0 Day Calib Ch2: 0 RPM Ch1: OFF RPM Ch2: OFF</p> </div>	<p>Days left until next calibration Stepper motor RPM Alarm Situation Ch1: left motor (see "maintenance" menu) Ch2: right motor (see "maintenance" menu)</p>
	<div style="border: 1px solid gray; border-radius: 10px; padding: 5px; width: fit-content;"> <p style="text-align: center;">Status</p> <p>Day Tube Ch1: 102 Day Tube Ch2: 102</p> </div>	<p>Days left to replace motor hose Ch1: left motor (see "maintenance" menu) Ch2: right motor (see "maintenance" menu)</p>
	<div style="border: 1px solid gray; border-radius: 10px; padding: 5px; width: fit-content;"> <p style="text-align: center;">Status</p> <p>Temperature: 85.4 °C VAC OUT 1: OFF VAC OUT 2: OFF</p> </div>	<p>Temperature read by the probe Current Output situation</p>
	<div style="border: 1px solid gray; border-radius: 10px; padding: 5px; width: fit-content;"> <p style="text-align: center;">Status</p> <p>P Ch1 (l/h): --- P Ch2 (l/h): 1200 % RPM Ch1: --- % RPM Ch2: 100</p> </div>	<p>Flow rate (litres per hour) and RPM of stepper motors Ch1: left motor Ch2: right motor</p>
	<div style="border: 1px solid gray; border-radius: 10px; padding: 5px; width: fit-content;"> <p style="text-align: center;">Status</p> <p>MC1 Flw release: 1.1.2 MC2 Flw release: 1.1.2 MC1 Error code: 0 MC2 Error code: 0</p> </div>	<p>Operating status of Motors Error Code (see Appendix "MC Error Code")</p>

The screenshots, here referring to model WNPGRH, are for illustrative purposes only and may differ.

6. Passcode

To access the "Main Menu", press the dial on the main screen and enter the Passcode. The Passcode to be entered upon first access is 0000 (default setting). Press the dial 5 times to access the "Main Menu". Otherwise, press the dial once and enter the Passcode. Select numbers by turning the dial.

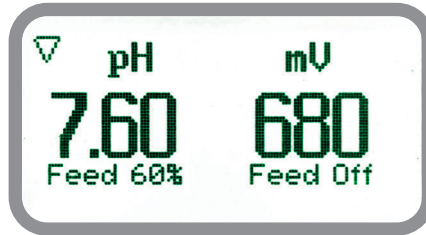

To set a new Passcode, choose "PARAMETERS" from the "Main Menu", highlight "New Pcode", press the dial and enter 4 numbers. Select "EXIT" and answer "YES" to save. The new Passcode is now active.

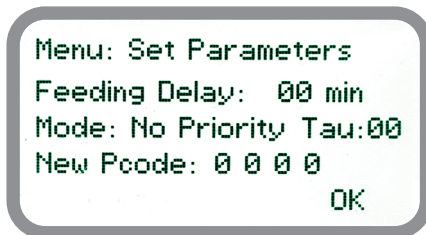

Forgot your passcode?

Be careful not to forget your Passcode (if changed). If you do, contact your local distributor for the unlocking procedure. The Passcode is in no way recoverable.

7. “Main Menu”

To access the “Main Menu” enter the Passcode (as described in the previous chapter). Turn the dial in the menu to scroll through the items and press to enter the submenu.

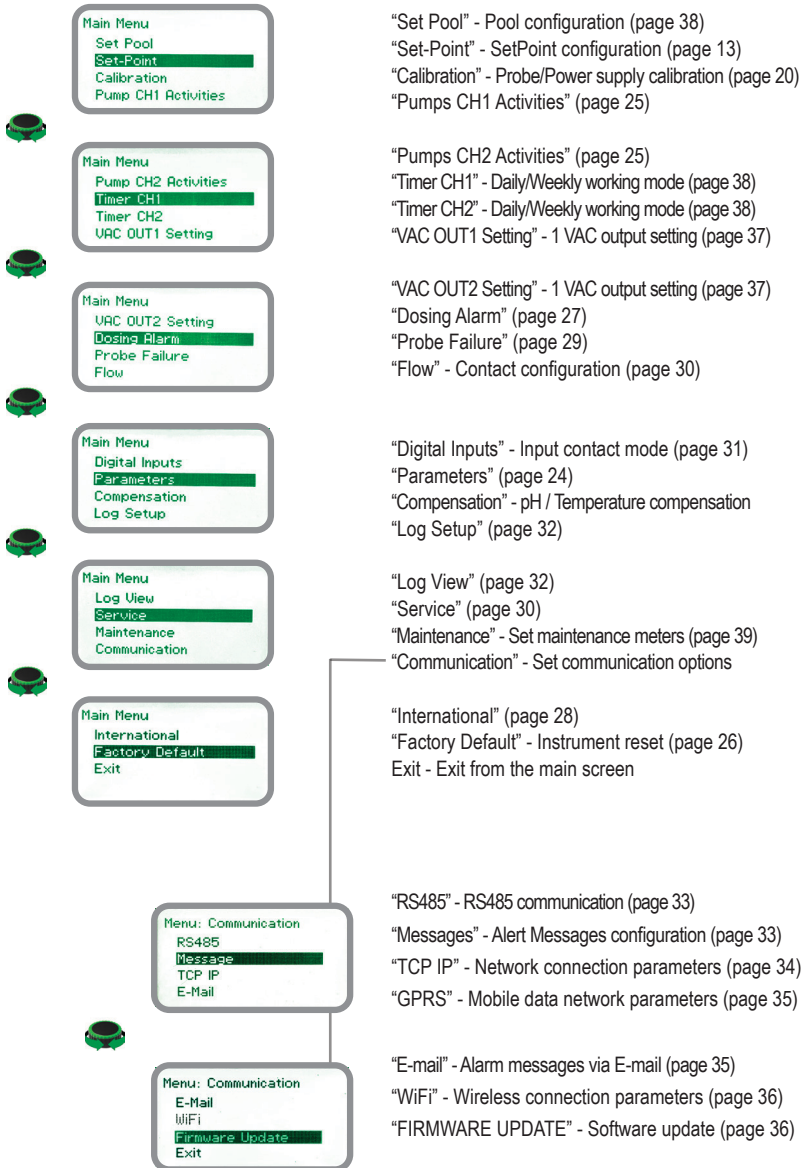

COMMUNICATION menu

8. "Set-Point", pH (on/off)

The pH reading value can be set to dose the pH pump using 2 set-points in **On/Off** or **Proportional (%)** and **auto-dosing mode**.

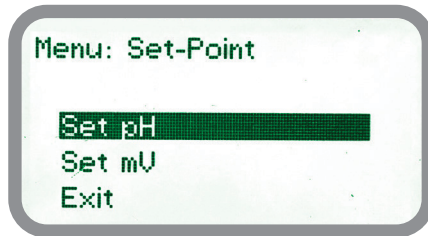

In **On/Off** mode, two values are set in the instrument that enable or disable the pH pump. To select this operating mode, highlight "Working Mode" with the cursor. Press the dial to select.

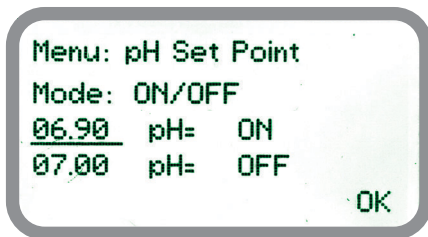

ALKALINE SOLUTION dosing ON/OFF mode

Set the pH value to 7.00 OFF and 6.90 ON.

The instrument will enable the pH pump until the reading is 7.00pH.

At 7.00pH the pump will be disabled until the reading drops to 6.90pH.

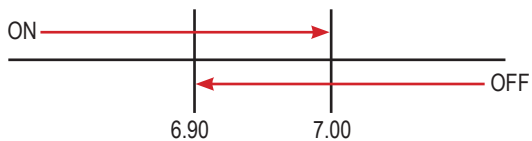

8.1 "Set-Point", pH (on/off)

ACID solutions dosing ON/OFF mode

Set the pH value to 7.00 OFF and 7.10 ON.

The instrument will enable the pH pump until the reading reaches 7.00pH.

At 7.00pH the pump will be disabled until the reading goes back up to 7.10pH

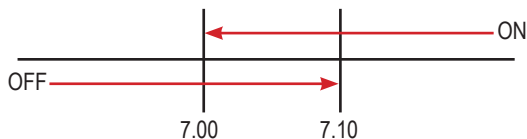

To finish the procedure, select "OK" and press the dial.

IN-DEPTH ANALYSIS

In chemistry, an alkaline substance is a base, ionic salt of alkali or alkaline earth metals.

They are very strong reducing agents, reacting violently with water to reduce its hydrogen (producing hydroxide ions (OH⁻) when dissolved in water). The adjective alkaline comes from the Arabic al-qali, and this term referred to potash, obtained as a by-product of wood combustion. Since potash has basic characteristics, the convention became widespread to call all substances that, like potash, are capable of neutralising acids "alkalis". So, even today, alkaline can mean either a metal from the first group of the periodic table or a basic compound.

An acid (often represented by the generic formula HA [H+A⁻]), according to the Arrhenius Theory, is a substance that dissociates into water and produces H⁺ ions. According to the more modern definition of Johannes Nicolaus Brønsted and Martin Lowry, an acid is a substance capable of yielding H⁺ ions to another chemical species, called a base. The Brønsted-Lowry theory extends the definition of a base to those substances whose behaviour in water cannot or is not practical to evaluate, as is de facto the case with the definition given by Arrhenius. He also introduces the concept of complementarity between acid and base, since the base is not such unless there is a counterpart from which it is possible to take an H⁺ ion, and vice versa. An acid-base reaction is therefore a reaction of one chemical species transferring protons to another species capable of accepting them. In such a reaction, the acid is transformed into its conjugate base. Thus the concept of complementarity between acid and base is introduced, since the acid is not such unless there is a counterpart from which to donate its H⁺ ion, and the base is not such unless there is a counterpart from which to accept an H⁺ ion. A substance is therefore not acidic or basic absolutely but relative to the reaction considered.

Acid-base reactions thus differ from oxidation-reduction (or Redox) reactions, in which instead there is a variation in the oxidation state of at least one element involved in the reaction.

8.2 "Set-Point", pH (proportional)

The pH reading value can be set to dose the pH pump using 2 setpoints in **On/Off** or **Proportional (%)** and **auto-dosing mode**.

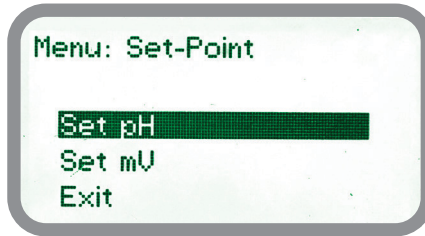

In **Proportional mode**, the working percentage calculated between two values that enable or disable the pH pump is set in the instrument. To select this operating mode, highlight "Working Mode" with the cursor. Press the dial to select.

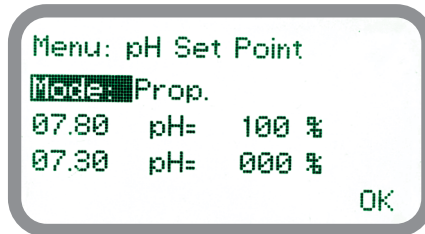
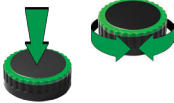

PROPORTIONAL MODE between 7pH(0%) and 8pH (100%).

In this mode, the pH pump will be switched on for values above 8pH with maximum dosing capacity and will be switched off for values below 7 pH. For values of 7.5 pH the pump will be switched on with a halved dosing capacity. To finish the procedure, select "OK" and press the dial.

8.3 "Auto Dosing", pH

This menu lets you use **AUTO DOSING** mode for each individual channel of the instrument. The parameters to be set are: Setpoint, i.e. the target to be reached through the control and dosing activity and whether the working mode should be based on lowering or raising the pH concentration values in the pool in order to reach the Setpoint (mode + or -). E.g.: if the pH concentration in the pool tends to be too high, set pH- to optimise reaching the Setpoint. **Note: in auto-dosing mode, the pH channel has priority over the Ch2 channel and it is not possible to set this mode for Ch2 only.**

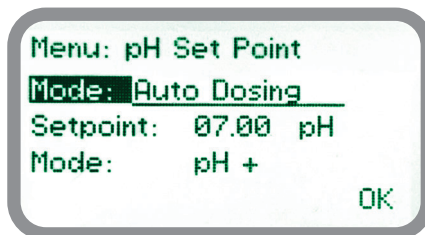

8.4 "Set-Point", Redox (on/off)

The mV reading value can be set to dose the Redox pump using 2 set-points in **On/Off** or **Proportional (%) mode**.

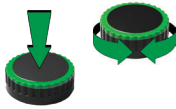

Menu: Set-Point

Set pH

Set mV

Exit

In **On/Off** mode, two values are set in the instrument that enable or disable the Redox pump. To select this operating mode, highlight "Working Mode" with the cursor. Press the dial to select.

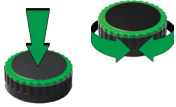

Menu: mV Set Point

Mode: ON/OFF

600 mV= ON

700 mV= OFF

OK

ON/OFF mode

Set the mV value to 600 mV ON and 700mV OFF. The difference between the two values is called **HYSTERESIS**.

The instrument will enable the Redox pump when the reading decreases to 600mV.

At 600mV the pump will remain enabled until the reading rises to 700mV.

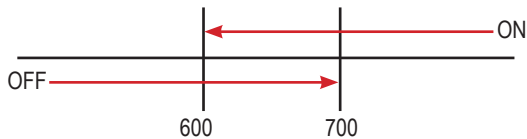

8.5 “Set-Point”, Redox (proportional)

The mV reading value can be set to dose the Redox pump using 2 setpoints in **On/Off** or **Proportional (%)** and **auto-dosing mode**.

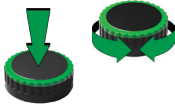

Menu: Set-Point

Set pH

Set mV

Exit

In Proportional mode, the working percentage calculated between two values that enable or disable the Redox pump is set in the instrument. To select this operating mode, highlight “Working Mode” with the cursor. Press the dial to select.



Menu: mV Set Point

Mode: Prop.

600 mV= 100 %

700 mV= 000 %

OK

PROPORTIONAL MODE between 700mV (0%) and 600mV(100%).

In this mode, the Redox pump will be switched on for values below 600mV with maximum dosing capacity (180 strokes) and will be switched off for values above 700mV. For values of 650mV the pump will be switched on with a halved dosing capacity. To finish the procedure, select “OK” and press the dial.

8.6 “Auto Dosing”, Redox

This menu lets you use AUTO DOSING mode for each individual channel of the instrument. The parameters to be set are: Setpoint, i.e. the target to be reached through the control and dosing activity and whether the working mode should be based on lowering or raising the Redox concentration values in the pool in order to reach the Setpoint (mode + or -). E.g.: if the Redox concentration in the pool tends to be too high, set mV- to optimise reaching the Setpoint. **Note: in auto-dosing mode, the pH channel has priority over the Ch2 channel and it is not possible to set this mode for Ch2 only.**



Menu: mV Set Point

Mode: Auto Dosing

Setpoint: 700 mV

Mode: mV +

OK

8.7 "Set-Point", Cl (on/off)

The Cl reading value can be set to dose the chlorine pump using 2 set-points in **On/Off** or **Proportional (%)** and **auto-dosing mode**.

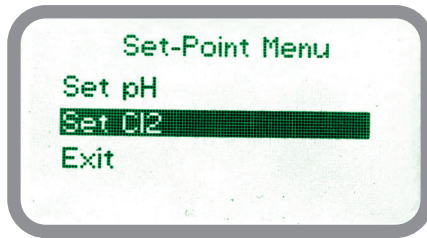

In **On/Off** mode, two values are set in the instrument that enable or disable the chlorine pump. To select this operating mode, highlight "Working Mode" with the cursor. Press the dial to select.

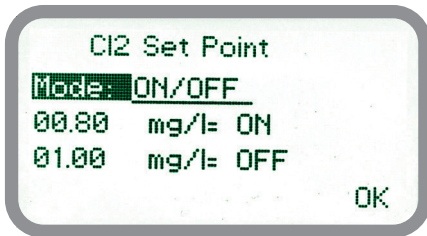

ON/OFF mode

Set the Cl value to 0.80 mg/l ON and 1.00 mg/l OFF. The difference between the two values is called **HYSTERESIS**. The instrument will enable the Chlorine pump when the reading decreases to 0.80mg/l. At 0.80mg/l the pump will remain enabled until the reading rises to 1.00mg/l.

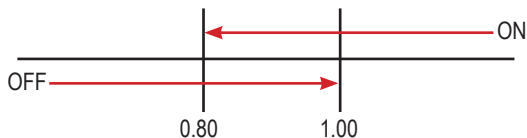

8.8 “Set-Point”, Cl (proportional)

The Cl reading value can be set to dose the chlorine pump using 2 set-points in **On/Off** or **Proportional (%)** and **auto-dosing mode**.

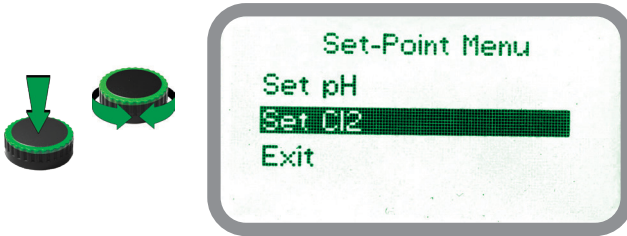

In **Proportional mode**, the working percentage calculated between two values that enable or disable the Chlorine pump is set in the instrument. To select this operating mode, highlight “Working Mode” with the cursor. Press the dial to select.

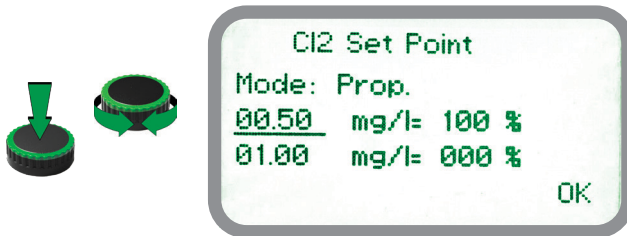

PROPORTIONAL MODE between 1.00Cl (0%) and 0.50Cl(100%).

In this mode, the chlorine pump will be switched on for values below 0.50 mg/l with maximum dosing capacity and will be switched off for values above 1 mg/l. For values of 0.75 mg/l the pump will be switched on with a halved dosing capacity. To finish the procedure, select “OK” and press the dial.

8.9 “Auto Dosing”, Chlorine

This menu lets you use **AUTO DOSING** mode for each individual channel of the instrument. The parameters to be set are: Setpoint, i.e. the target to be reached through the control and dosing activity and whether the working mode should be based on lowering or raising the Chlorine concentration values in the pool in order to reach the Setpoint (mode + or -). E.g.: if the Chlorine concentration in the pool tends to be too high, set Cl2- to optimise reaching the Setpoint. **Note: in auto-dosing mode, the pH channel has priority over the Ch2 channel and it is not possible to set this mode for Ch2 only.**

9. "Probe Calibration", pH

pH calibration can be carried out on two points (P1 and P2) in FULL CALIBRATION mode and therefore requires two buffer solutions. The default buffer solutions are pH4.00 and pH7.00.

Choose "pH probe" from the "Calibration Menu".



```
Menu: Calibration
Calibration pH
Calibration mV
Temperature Probe
Exit
```

In the following example, the pH reading will be calibrated using the default buffer solutions

Caution: this procedure assumes that the instrument is correctly installed, configured and connected to a functioning pH probe. Otherwise, the results may not be reliable.



```
Calibration pH
P1 Reading Cal. at
P2 7.60 07.00
Ex
Exit OK
```



pH7

1st point calibration (P1).

Select "P1" from the "pH Calibration" menu" and press the dial to enter the first point to be calibrated. Prepare the 7.00pH buffer solution and immerse the probe sensor in it. Wait for the value to stabilise. Enter the buffer solution value in the "Cal. at" field. Press to confirm. To complete the procedure, move the cursor to "OK" and press to proceed to the next step.

Caution: the value of the buffer solution may undergo variations if the ambient temperature is different from 20°C. Read the buffer solution label for further information. In this case the "Default pH" value must be changed.

9.1 "Probe Calibration", pH

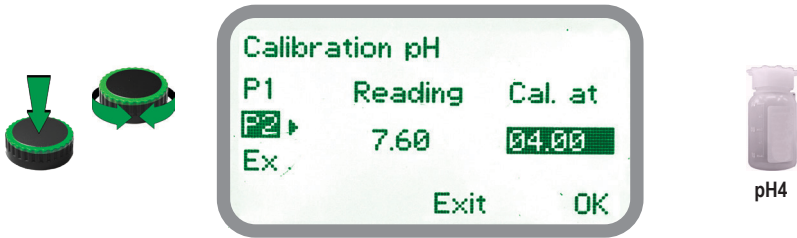

2nd point calibration (P2).

Select "P2" from the "pH Calibration" menu and press the dial to enter the second point to be calibrated. Prepare the 4.00pH buffer solution and immerse the probe sensor in it. Wait for the value to stabilise. Enter the buffer solution value in the "Cal. at" field. Press to confirm.

To finish the procedure, select "OK" and press the dial.

Caution: the value of the buffer solution may undergo variations if the ambient temperature is different from 20°C. Read the buffer solution label for further information. In this case the "Default pH" value must be changed.

9.1 "Probe Calibration", Temperature

A professional temperature thermometer is required to complete this procedure correctly.

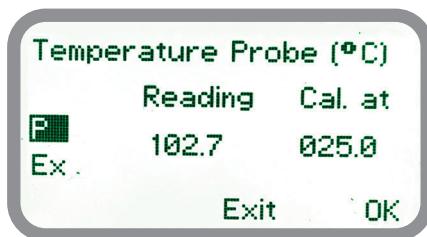

Choose "Temperature probe" from the calibration menu.

Note: This procedure considers the instrument installed and correctly configured. In particular, the PT100 temperature probe must be installed in its final location in the plant. Otherwise, unreliable results would be obtained.

Once the temperature has been detected on the thermometer, change the "Cal. at" field by entering the value in degrees, then confirm by pressing the dial.

9.2 "Probe Calibration", mV - Redox

Redox calibration requires the use of a buffer solution with a value close to the working value. Choose "mV probe" from the "Calibration Menu".

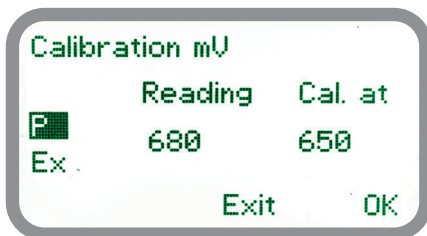

Caution: this procedure assumes that the instrument is correctly configured, is connected to a functioning Redox probe and is installed on the system. The measurement must be made using water from the plant. Otherwise, the results may not be reliable.

Calibration can be carried out using one of the following methods: calibration using a buffer solution or by reading the residual chlorine and using the comparison table. The choice is exclusively at the user's discretion. In both cases, however, calibration is necessary if the instrument is being installed for the first time. Calibration using a buffer solution is used in the example below.

- 1) Measure the temperature of the buffer solution and make sure that it corresponds to what is written on the solution label.
- 2) Remove the protective cap from the Redox probe and wash the tip of the probe with water. Leave to dry, shaking it in the air.
- 3) Set the value of the buffer solution in the "mV Def" field on the instrument. Insert the probe tip into the buffer solution and wait for the reading in the "mV" field to stabilise. Then move the cursor to "OK" and press the dial. If the procedure fails ("Calibration Failed") repeat the procedure again, paying attention to the probe reading value. To exit without calibrating, move the cursor to "Ex" and press the dial.

REDOX - mg FREE CHLORINE - pH GRAPHIC TABLE

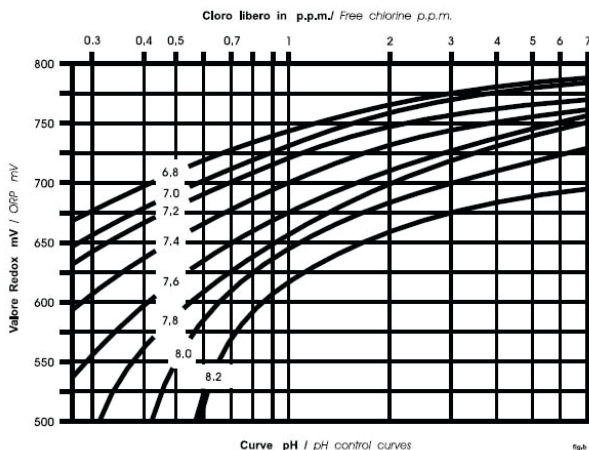

9.3 "Probe Calibration", Cl

Chlorine calibration requires selection of the probe, calibration of the zero point (P1) and the second point (P2). Choose "Cl probe" from the "Calibration Menu".

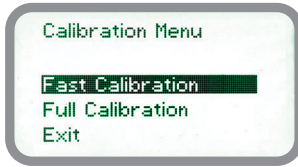

Select "FULL CALIBRATION" the first time the instrument is started or when using a new probe for the first time.

This procedure uses two reference points: P1 (Zero) and P2 (Second Point).

Select "FAST CALIBRATION" for the monthly calibration. This procedure only requires P2 (Second Point) to be calibrated.

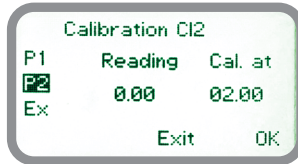
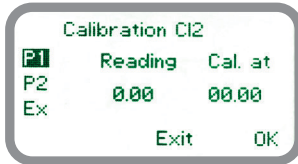

Caution: this procedure assumes that the instrument is correctly configured, is connected to a functioning Chlorine probe and is installed on the system. The measurement must be made using water from the plant. Otherwise, the results may not be reliable.

Zero point calibration (P1).

In the "Cl calibration" menu, move the cursor to "P1" and select it to enter the calibration
For correct calibration:

- Install an "active carbon filter" in the probe holder (not necessary for ECL6).
- Run water inside the probe holder for 30 minutes.
- Press the dial with the cursor set to "Cal.at".
- Remove the filter (not necessary for ECL6).



Active carbon filter system

2nd point calibration (P2) also for FAST mode only.

Move the cursor to "P2" and select it to enter the calibration procedure.
For correct calibration, use a photometer or DPD system to read the chlorine in the plant.
Enter the value read in the "Cal. at" field.



Photometer

If an error occurs during calibration, the instrument will signal this with a message and request a new calibration. Delete current settings or restore default values.

10. "Parameters"

Choose "Parameters" from the "Calibration Menu". From this menu it is possible to:

- Delay the pump dosing start (max. 60 minutes);
- Set the pH pump to have priority over the Redox pump at start-up;
- Change the default Passcode.

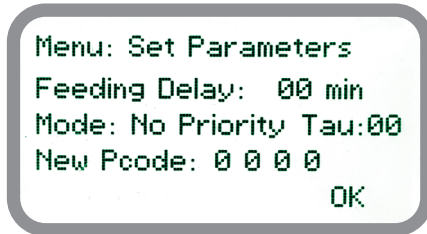

TAU (if available)

If the values read by the second probe change very quickly it may be useful to increase the TAU value. The standard value is: 05. The maximum value is: 30.

Feeding Delay (delayed dosing start).

Move the cursor to "Feeding Delay" and press to select. Choose a value between 0 (disabled) and 60 minutes (maximum delay that can be set). This function can be used to delay start-up of the pumps. The delayed start is activated when the instrument is switched on or after resetting following a "NO FLOW" alarm.

Mode (Dosing priority).

Move the cursor to "Mode" and press to select. If both pumps have to dose, it is possible to set the pH pump to have priority over the Redox pump at start-up. Select "pH priority" to enable this option. The Redox pump will begin dosing when the pH pump has finished dosing.

New Pcode.

To update the access Passcode for the instrument, enter the new numerical sequence here. See page 11.

11. "Pump CH1 Activities / Pump CH2 Activities"

The "Pumps CHx activities" menu lets you manually operate the two stepper motors of the instrument. CH1 refers to the left motor of the instrument while CH2 refers to the right one. From this menu, it is possible to set the stepper motor operation from automatic (mode: "AUTO") to manual for a settable time ("MAN"), to disable it permanently ("OFF") and the direction of rotation (e.g. "PRIME" for priming with clockwise rotation).

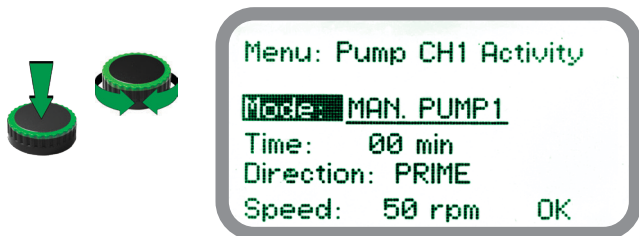

In manual operation mode to adjust the timer, press the knob and move the cursor to the "TIME" field. Then set a time between 0 (pump disabled) and 99 minutes. Move the cursor to "OK" and press the knob.

To set the stepper motor rotation speed, move the cursor to the "Speed" field, then press the dial and choose the RPM at which you want the stepper motor to rotate.

Move the cursor to "OK" and press to confirm. Exit from the menu. A countdown will be displayed on the main screen for the selected pump (on the left for the pH pump, on the right for the Redox pump). To block this countdown, go back to the "Pump Activity" menu and choose "ON" as working mode and wait for the end of the countdown.

12. "Factory Default" - Instrument reset

To reset the instrument to its default values (including Passcode), go to the "Factory Default" menu and press the dial and display "ON". Press again, move to "OK" and press to confirm. The message "WAIT" will appear above "OK". After a short wait, the instrument will return to the "Main Menu". Move to "EXIT" and press. The instrument will reload the factory settings. It will then be necessary to repeat all calibration and parameter programming procedures.

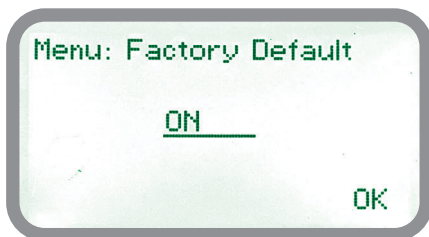
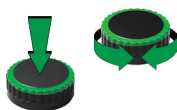

13. "Dosing Alarm"

Use to set a maximum time within which the pumps must reach the setpoint.

If the pumps continue dosing after this time has elapsed, it is possible to stop them via this menu or to display an alarm message. This function can be disabled by selecting "OFF" instead of minutes. The dosing alarm can be set for one or both pumps.

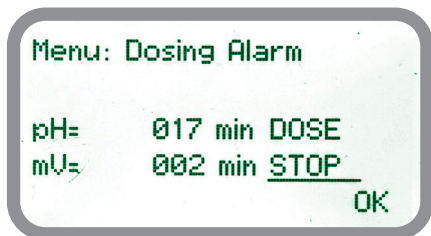

EXAMPLE ON THE "WNPHRH" INSTRUMENT:

Set the Redox pump to stop at the end of the set time if the setpoint has not been reached.

Press the dial, set the time, move to the "DOSE" / "STOP" field and choose "STOP". The time can be set from 0 to 100 minutes. At the end, move the cursor to EXIT and press the dial.

To finish the procedure, select "OK" and press the dial.

14. "International"

This menu lets international parameters to be set for:

- Time/date format (Europe IS or USA)
- The time
- The date
- The language



Format.

This option changes the time/date format (European or American). See the table for differences.

EUROPE IS (International Standard)	USA
Date (DD/MM/YY)	Date (MM/DD/YY)
Time 24h	Time AM / PM

Time.

Set the local time using this option.

Date.

Set the date using this option.

Language.

Use this option to set the language of the instrument interface. Additional languages will be added with future software updates.

When finished, move the cursor to OK and press the dial.

15. "Probe Failure"

This menu lets you set a probe check time. If the probe reading remains fixed over the set time, the probe is most likely damaged.

It is possible to stop the pumps or to display an alarm message (probe failure) using this menu. This function can be disabled by selecting "OFF" instead of minutes. The alarm can be set for one or both pumps.



EXAMPLE ON THE "WNPHRH" INSTRUMENT:

Set the Redox pump to stop at the end of the set time if the value read by the probe has not changed.

Press the dial, set the time, move to the "DOSE" / "STOP" field and choose "STOP". The time can be set from 100 to 254 minutes. To finish the procedure, select "OK" and press the dial.

16. "Flow" - No Flow contact configuration

The FLOW contact (connections page 4) can be enabled to interrupt the dosing procedure using N.O. (normally open contact) or N.C. (normally closed contact). Turn the dial to select the most suitable type of operation between: "DISABLE", "REVERSE" (N.O. contact) or "DIRECT" (N.C. contact). The FLOW contact can also interrupt the dosing procedure after a certain time interval has elapsed since the contact was closed (or opened). To set the time interval turn the dial to "Time:00 min", press and turn to change the interval (from 0 to 99 minutes). Press again to confirm the setting.

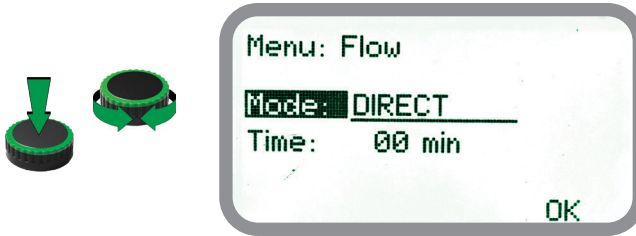

To finish the procedure, select "OK" and press the dial.

17. "Service"

This control menu cannot be modified and shows the current reading of the probes. Turn the encoder to view the QR Code to identify the pump during registration for advanced connectivity services (APP and ERMES Digital Services).

Press "OK" to exit.

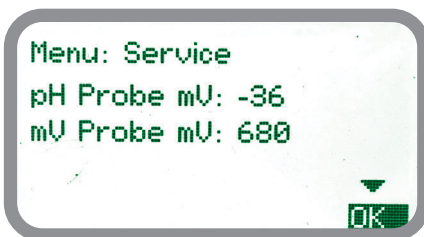

Real time probe reading data



Serial number or QR Code for registration for advanced connectivity services.

18. "Digital Inputs" - Input contact mode

Use this menu to set the operating mode of the inputs on the board. The type of contact for each input can be set to N.O. (normally open) or N.C. (normally closed).

WNPHRH version

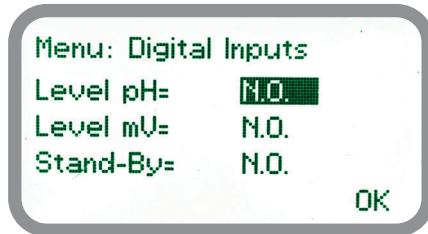

To change the contact, use the dial to select the item, press and turn again to choose between N.O. or N.C.

19. "LOG SETUP" - Activity log setting

If enabled, this function allows logging of instrument activities (date, time, temperature, alarms, uS, totaliser, outputs) for a set period (EVERY) starting from a set time (TIME).

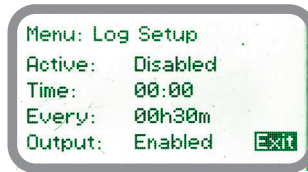

Highlight "DISABLE", turn the dial and select "ENABLE". Set:

ACTIVE: LOG activity enabled or disabled

TIME: start time of logging of events (log) (format 23h and 59min)

EVERY: logging frequency of events (log) (23h and 59min format)

OUTPUT: output activity log

20. "LOG VIEW" - Shows activity log

To view the latest instrument alarm activity, select this item from the main menu.

SETTING THE DATE AND TIME BEFORE ENABLING LOGGING. The instrument will lose the current date and time if it has not been powered for approximately 30 days.

21. "RS485" - Communication port setting

Set an ID number (ID485 = 01) and a name before using the advanced communication functions (e.g. alarm service via SMS or remote communication). Then check with ID CHECK if it has already been assigned, in which case an error message will appear. If it does, choose another number.

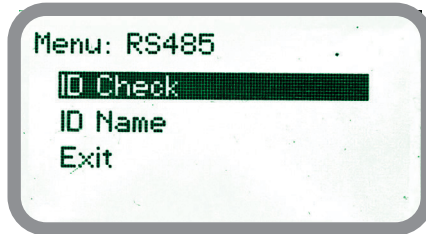

22. "Message" - Settings for sending alarm messages

This menu can be used to select the type of alarm message that will be sent to the user via the email messaging service configured in the "Email" menu.

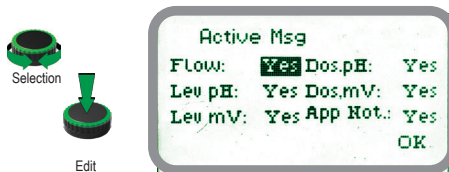

- Carefully set this menu to prevent UNWANTED MESSAGES.
CAUTION: SENDING SMS MESSAGES MAY NOT BE FREE OF CHARGE.

ACTIVE MSG

Flow: flow alarm

pH Lev: pH level alarm

mV Lev: mV level alarm

pH: pH dosing alarm (see "dosing alarm menu")

mV: mV dosing alarm (see "dosing alarm menu")

App Not.: Enables notifications to be sent to the MYEMEC companion app.

23. "TCP/IP" - TCP/IP configuration for Ethernet connection

The instrument can be managed remotely using a standard ETHERNET connection (upon request). A static or dynamic IP address and a CAT5 Ethernet cable are required for this configuration. Depending on the network used, the connection speed is 10/100Mbps. Contact your network administrator for IP address and SUBNET MASK data.

Enter the parameters, move the cursor to "SAVE" to store, then to "YES" and press the dial to save and enable the configuration.

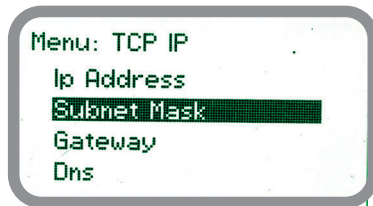

Depending on your configuration network, choose "Dynamic" (the instrument will receive network parameters automatically) or 'Static' (manual data input) configuration type.

In-depth analysis: Static IP and Dynamic IP address.

Dynamic Host Configuration Protocol (DHCP) is a protocol that allows network devices to receive the IP configuration required to operate on an Internet Protocol-based network.

In an IP-based network, each computer requires an IP address, chosen in such a way that it belongs to the sub-network to which it is connected and that it is unique, i.e. there are no other computers already using that address.

The task of manually assigning IP addresses to computers places a considerable burden on network administrators, especially in large networks or where there are numerous computers that only connect on a rotational basis at certain times or days. Furthermore, IPv4 addresses (currently used in almost all networks worldwide) have become scarce as more and more computers are connected to the Internet, thus reducing the availability of fixed IP addresses.

DHCP is mainly used in local networks, particularly on Ethernet. In other contexts, similar functions are performed within PPP.

DHCP protocol is also used to automatically assign various parameters to the computer which are necessary for its proper functioning on the network to which it is connected. The most common of these, in addition to dynamic IP address assignment, include:

- Subnet mask
- Default Gateway
- DNS server addresses
- Default DNS domain name

These parameters can be entered manually if you have a static IP address with manual DHCP.

24. "GPRS" - GPRS configuration for connection via mobile network

"GPRS" menu

The instrument can be operated remotely via optional GPRS modem.

Check the following points before activating this service:

- The antenna must not be shielded by metal objects or placed near sources of electromagnetic interference.
- The distance between the antenna and the instrument must be within the limits of the cable length (approx. 2 m).
- The cable must not be crushed in doors/windows.
- Verify insertion of the SIM card in the instrument modem, its operation and the presence of the operator.

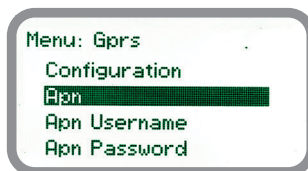

Refer to your mobile phone operator's configuration to enter the data correctly.

It is possible to set the instrument to connect to ERMES for remote control services (select "ERMES YES" from the "Configuration" menu), to receive only warning messages (select "ERMES NO" from the "Configuration" menu), to set the APN (access point name), username and Passcode for access to the operator's network and the SIM telephone number.

Note: Don't forget to disable the SIM PIN request by entering the unlock code in the PIN NUMBER sub-menu.

CAUTION: SENDING SMS MESSAGES MAY NOT BE FREE OF CHARGE.
DATA TRAFFIC VIA TEXT MESSAGE, REGULATED BY THE CONTRACT WITH THE NETWORK OPERATOR, MAY HAVE A COST

If the Ethernet module or GPRS modem is installed, the instrument can send alarm emails. Up to 2 email addresses can be entered from the "Email" menu; these will receive the alarms configured in the "ACTIVE MSG" sub-menu of the "GSM" menu.

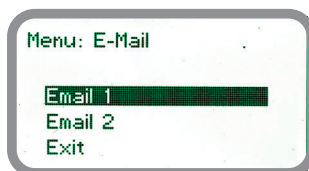

In-depth analysis: APN

The Access Point Name or APN is the name of an access point for GPRS or UMTS networks. An access point is:

- An Internet network to which a mobile device can be connected
- A configuration point used for the connection
- A particular option that is configured on a mobile phone

There are various types of APNs and they can be used in both public and private networks. For example: ibox.tim.it; web.omnitel.it; internet.wind; tre.it
Once the device is connected, it will use the DNS service to resolve the APN call process, which will return the real IP address of the access point.

25. WIFI connection

Choose "WIFI" in the "Communication" menu to set up the wireless connection to a compatible router. Wait for the instrument to scan the available networks and choose the desired one from the list that will appear at the end of the search. Otherwise, click on "SCAN" to repeat the search. Enter the WEP / WPA / WPA2 Passcode (if necessary) and wait for the connection. Once connected, the Wi-Fi signal indicator will appear. To obtain a reliable connection, make sure to install the instrument within the WiFi range. Check your router specifications and installation procedure to obtain the best results.

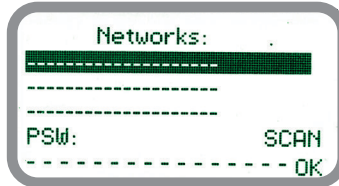

26. SOFTWARE UPDATE

If available, it is possible to update the instrument software to the latest version via this menu. **Before you can perform this procedure, make sure that the instrument is connected to a WiFi network with internet connectivity.** Then enter the "Firmware Update" menu, select "Control Update" and then choose "ON". Wait for the new firmware to appear and then select "OK". Select the "Download Firmware" menu and confirm that you want to perform the update. Wait for the operation to be completed.

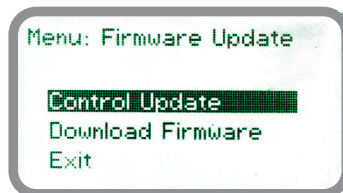

27. VAC OUT - Voltage outputs (Max Load 5A Resistive)

This menu can be used to configure the operating mode of the two outputs (VAC OUT1 and VAC OUT2).

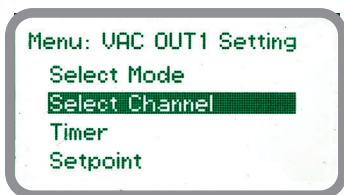

Select Channel.

Select and assign the VAC OUT channel with the corresponding pH, Redox or Chlorine reading channel.

Select Mode.

Set the working mode to "Setpoint", "Timer" or "off" (disabled). In "Setpoint" mode, the output can be configured in Proportional or On/Off mode (**Setpoint Menu**) and therefore activated/deactivated until the set value for the pH or Redox/Chlorine channel is reached in proportional or on/off mode. In "Timer" mode, the output will be active for a set period of time ("**Timer**" menu) within a week, a day or for a specific duration.

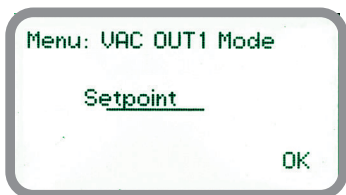

Set the working mode between proportional or on/off in the "Setpoint" menu.

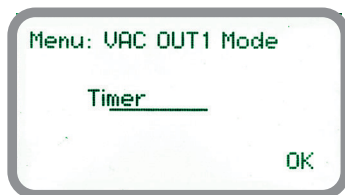

Set the working mode between "Daily" and "Weekly" in Timer mode.

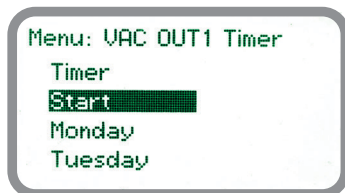

Start. Start activity.

Timer. Output activity duration.

Monday...Sunday. Days of output activity.

28. SET POOL - Pool size setting

This menu can be used to set the size of the pool in cubic metres and the size of the internal hoses of each peristaltic pump to automatically regulate dosing.

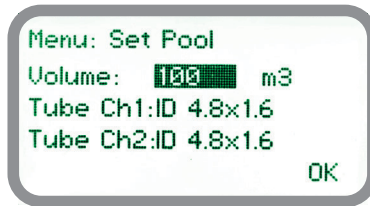

Ch1 is the left peristaltic stepper motor. Ch2 is the right peristaltic stepper motor. To confirm the changes, move the cursor to OK and then press the dial.

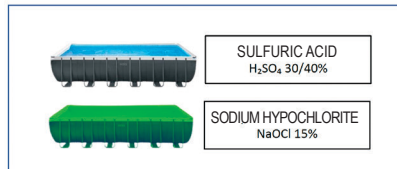

POOL mc	Hysteresis Firt Run	Max Dosage First Run H_2SO_4	Max Dosage First Run NaOCl
1	3'	15 cc/h	30 cc/h
10	5'	130 cc/h	250 cc/h
30	6'	350 cc/h	700 cc/h
50	6'	500 cc/h	1000 cc/h
100	8'	1000 cc/h	2000 cc/h
150	10'	1500 cc/h	3000 cc/h
200	15'	2000 cc/h	4000 cc/h
250	20'	2500 cc/h	5000 cc/h

29. TIMER CH1 / CH2 - Daily / weekly working mode setting

This menu can be used to configure "Timer" operating mode with daily or weekly dosing for each individual channel of the instrument. The parameters that can be set are "MODE": "Daily" or "Weekly". Furthermore, it is possible to activate or deactivate individual days of the week by choosing the day (Monday...Sunday).

Use "Timer" to set the maximum dosing duration of each activity session (in minutes).

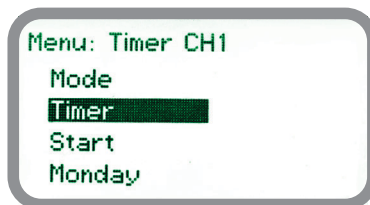

30. MAINTENANCE - Meters for maintenance operations

This menu displays the usage status of the stepper motors and internal tubes based on a count of revolutions and hours backwards. To access this menu and reset the counters, you need to use an additional Passcode. Ask technical support or your reference dealer.

When it is necessary to intervene on the wear of the tubes, a "warning" alarm message will be displayed on the main screen under the affected channel. The display will turn yellow.

Check the situation from the "status" menu by performing a complete rotation of the encoder.

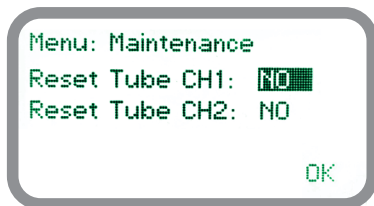

WARNING:

The performance of the tubes in peristaltic pumping applications is influenced by the conditions of use, the equipment used and the type of liquid dosed. The limits set for the maintenance counters refer to the operation of the pump at 1 bar of back pressure, 23°C of ambient temperature and dosing liquids that are not particularly corrosive.

Appendix. Dimensions (mm)

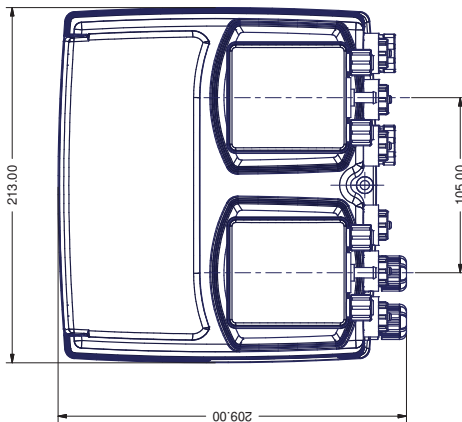
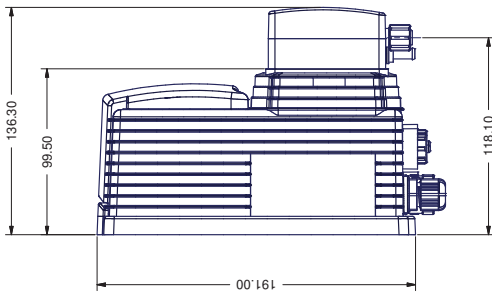
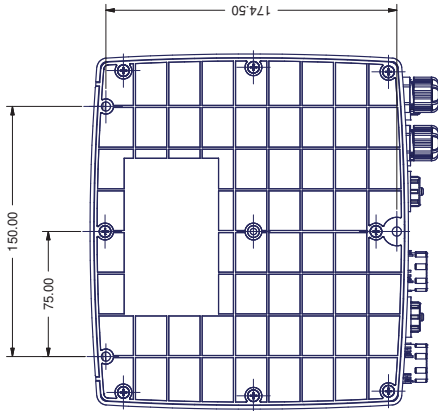

Appendix. Stepper Motor “MC” error codes

View any errors via the STATUS summary screen.

Error Name	MC Code	Description
MC_ERR_DOWN	1	Motor not working
MC_ERR_WRONG_VOLTAGE	2	Incorrect primary power supply voltage
MC_ERR_HW_OVERCURRENT	3	Overcurrent above the maximum tolerable threshold
MC_ERR_OPEN_LOAD	4	Open load detected (motor cable disconnected)
MC_ERR_THERMAL_SHUTDOWN	5	Device overheating threshold reached
MC_ERR_MO_INACTIVE	6	Motor control inactive
MC_ERR_COMM_TIMEOUT	7	Motor stopped because maximum time (10 sec) reached without messages from the master
MC_ERR_CMEM_ERR	8	Checksum error in reading/writing the configuration parameters in the volatile memory
MC_ERR_WDOG_REBOOT	9	Indicates that the micro has been restarted due to watchdog timeout
MC_ERR_WRONG_SPEED	10	Position error detected by the position sensor
MC_ERR_POS_SNS_FAIL	11	Position sensor inactive
MC_ERR_OVER_TEMP	12	Motor zone overtemperature
MC_ERR_COMM_DOWN	13	No communication with the master motors

Appendix. Operating logic and installation diagram

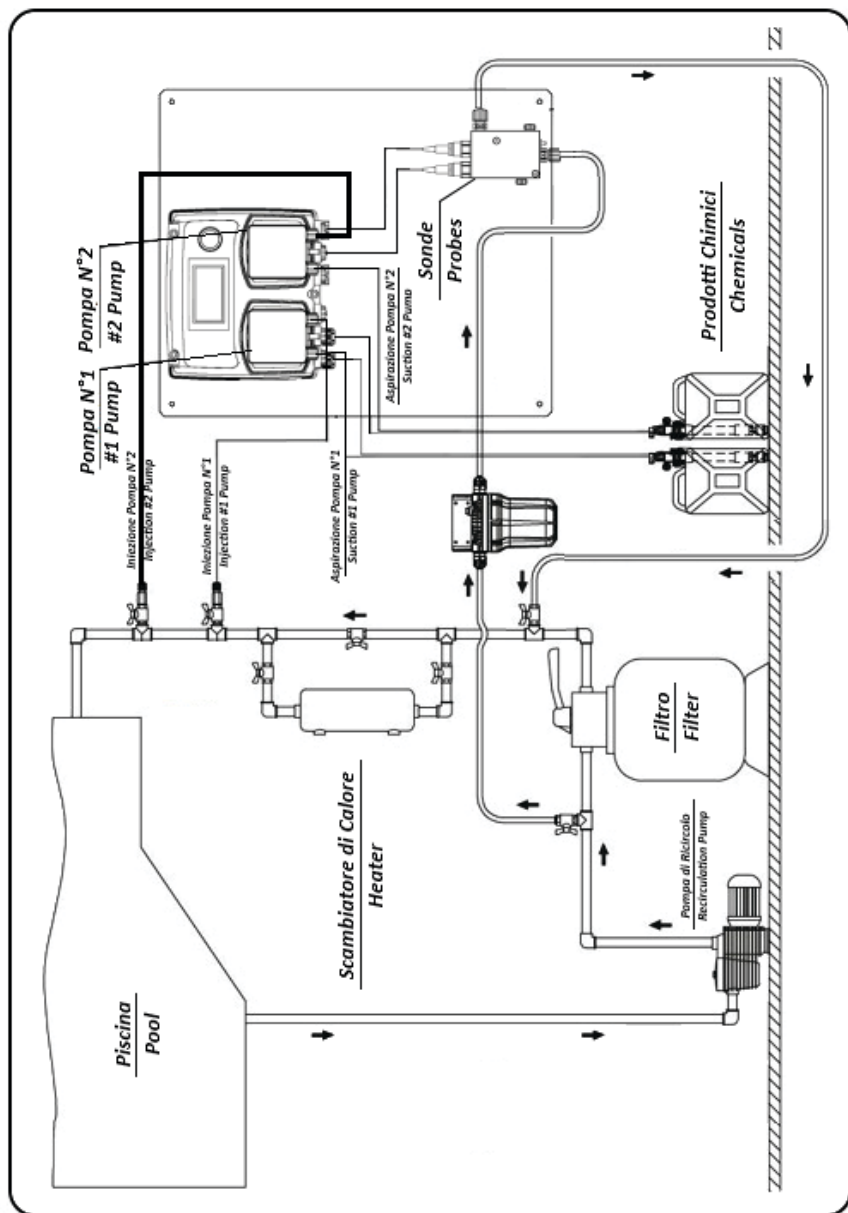

Appendix. Replacing the peristaltic hose

Replacement procedure for the Semi-Assembled Hose + WN Peristaltic Pump Slide

Useful/necessary material

- New semi-assembled hose + slide (Necessary)
- Compass wrench with $\text{ØD}=4\text{mm}$ and $A=19.7\text{mm}$ (Useful)



Operating Steps

1. Preparing the Pump

- Switch off the pump and disconnect it from the mains to ensure safety.
- Close any delivery and suction valves to prevent liquids from leaking out.
- Drain the residual fluid from the peristaltic hose.

2. Removing the Old Semi-Assembled Part

- Open the pump cover to access the slide and the hose.



3. Remove the rotor cover disc.



4. Remove the slide with the worn hose, being careful not to damage the rollers or the pump body.



5. Insert and secure the slide with the new hose in the pump, making sure it is correctly aligned.



Appendix. Replacing the peristaltic hose

6. Move the hose into position using the compass wrench or by hand, by rotating the Roller Holder and guiding the hose by pressing towards the inside of the Pump Body.



7. Check and Test

- Manually rotate the rollers to make sure that the hose is correctly positioned and that it can move freely.

- Reposition the Rotor Cover Disc.



- Close the pump cover.

- Turn the power back on and start the pump for a no-load test.



General notes on safety



During an emergency of any kind in the room where the pump is installed, immediately cut off the power to the system and disconnect the pump from the power socket!

If particularly aggressive chemical materials are used, regulations on the use and storage of these substances must be strictly followed!

Always observe local safety regulations!

The dosing pump manufacturer cannot be held liable for damage to persons or property caused by improper installation or use of the dosing pump!



Failure to activate the Min/Max alarm, or rather the maximum dosing alarm, can lead to dangerous overdosing!



Install the dosing pump so that it is easily accessible whenever maintenance is required! Never obstruct the location of the dosing pump!

The instrument must be connected to an external control system. In the event of a water shortage, dosing must be stopped.

Service and maintenance of the dosing pump and all its accessories must always be carried out by qualified personnel!

Before any maintenance work, always drain the dosing pump connection pipes!



Always carefully empty and wash any hoses that have been used with particularly aggressive chemical materials! Wear the most suitable safety equipment for the maintenance procedure! **Carefully read the chemical characteristics of the product to be dosed!**

BEFORE CONNECTING THE APPLIANCE TO THE ELECTRICAL MAINS, CHECK:



- THAT THE POWER SUPPLY PARAMETERS CORRESPOND TO THOSE OF YOUR ELECTRICAL SYSTEM BY CHECKING THE LABEL ON THE SIDE



- THAT THE ELECTRICAL SYSTEM IS EQUIPPED WITH PROTECTION SYSTEMS AGAINST OVERLOAD, SHORT CIRCUITS AND EFFICIENT EARTHING

PRECAUTIONS RELATING TO DIRECTIVES, REGULATIONS AND STANDARDS

§ CE/EU and UKCA marking

We guarantee that this product meets the essential requirements of the applicable Directives and Regulations based on the following specifications. Please carefully consider the following specifications for use of the product in European Union member countries and the United Kingdom.

• CE/EU harmonized directives and standards

Directives

DIRECTIVE 2006/42/EC
DIRECTIVE 2014/35/EU
DIRECTIVE 2014/30/EU
DIRECTIVE 2011/65/EU
DELEGATED DIRECTIVE (EU) 2015/863

Harmonized standards

EN ISO 12100
EN 809
EN ISO 20361
EN IEC 61326-1
EN 61010-1
EN IEC 63000

• UKCA harmonized regulations and standards

Regulations

2008 No. 1597
2008 2016 No. 1091
2016 No. 1101
2012 No. 3032

Harmonized standards

BS EN ISO 12100
BS EN 809
BS EN ISO 20361
BS EN IEC 61326-1
BS EN 61010-1
BS EN IEC 63000

Contents

Models	page 2
Introduction.....	page 3
Dial	page 3
Connections.....	page 4
Hydraulic connections, pipes.....	page 6
Hydraulic connections, level probe.....	page 7
Main screen.....	page 8
Quick status check	page 10
Passcode.....	page 11
Main menu.....	page 12
“Set-Point” - setpoint operating mode setting	page 13
“Calibration” - Probe/Power supply calibration	page 20
“Parameters”	page 24
“Feed” - Stepper motor setting	page 24
“Pumps CH1 Activities” Pump 1 operations	page 25
“Pumps CH2 Activities” Pump 2 operations	page 25
“Factory Default” - Instrument reset	page 26
“Dosing Alarm”	page 27
“International”	page 28
“Probe Failure”	page 29
“Flow” - Contact configuration	page 30
“Digital Inputs” - Input contact mode	page 31
“Service”	page 30
“Log Setup”	page 32
“Log View”	page 32
“RS485” - RS485 communication	page 33
“Message” - Alarm Message Sending configuration	page 33
“TCP IP” - Network connection parameters	page 34
“GPRS” - Mobile data network parameters	page 35
“E-mail” - Alarm messages via E-mail	page 35
“WiFi” - Wireless connection parameters	page 36
“FIRMWARE UPDATE”	page 36
“VAC OUT1 Setting” - 1 VAC output setting	page 37
“VAC OUT2 Setting” - 1 VAC output setting	page 37
“Set Pool” - Pool size	page 38
“Timer CH1” / “Timer CH2” - daily/weekly mode	page 38
“Maintenance” - maintenance meters	page 39
Appendix. Dimensional.....	page 40
Appendix. Stepper motor setting	page 41
Appendix. Operating logic/installation diagram	page 42
Appendix. Peristaltic hose replacement procedure	page 43



Disposal of end-of-life equipment by users

This symbol warns against disposing of the product with normal waste. Respect human health and the environment by delivering the discarded equipment to a designated collection point for the recycling of electronic and electrical equipment. For further information please visit the online site.



All materials used in the construction of the dosing pump and for this manual can be recycled and thus help to preserve the incalculable environmental resources of our Planet. Do not dispose of harmful materials in the environment! Enquire with the relevant authority about recycling programs for your area!